**MONOBLOC
RANGE SUMMARY**

VARTA Vb batteries are vented lead-acid batteries designed for industrial applications in power supply with high safety requirements. These monobloc batteries can be used for both long duration discharge (hours) and short duration discharge (minutes). The main areas of application are DC power supply systems in power stations and substations, UPS systems, industrial systems and emergency power supply systems. They can also be used for engine starting and for energy storage in solar power systems.

The special rod plate design of **VARTA Vb** batteries offers a high energy density and a long life time in one unique design. This gives better performance and can minimise the use of valuable floor space. Built-in transport handles on the lid allied with the unique **VARTA Vb** safety pole terminals make this a superior battery design. A very long topping up interval minimises service requirements to complete the package.

Features

- **Capacity range: 33 Ah – 246 Ah**
- **6V and 12V monobloc batteries**
- **Water topping up interval about 5 years in standby operation mode at 20°C**
- **Long service life due to proven VARTA rod plate technology and VARTA safety plugs**
- **Cover for vent plugs and transport handles integrated in battery lid, plain side walls**
- **Optimised plate design results in increased capacity of 20% to 35% in the DIN container**



Construction

Positive Electrode - Rod plate with low antimony lead alloy

Negative Electrode - Pasted grid plate

Separation - Micro-porous separator, combined with glass fibre mat

Casing Material - Acrylo-nitrile-butadiene-styrene (ABS), impact resistant, transparent, with electrolyte level indication, i.e. Max / Min

Electrolyte - Dilute sulphuric acid, density = 1.24 kg/l

Terminal Design - Leak-proof VARTA safety pole with brass insert and M8 stainless steel bolt

Connectors - Solid copper connector (20mm x 3mm) insulated, bolted type, voltage measurement possible

Vent Plugs - Flame arrestor VARTA safety vent plugs, optional: ceramic funnel plugs

Operation

- Float charge voltage: 2.23 Vpc at 20°C
- Suitable for all types of installation
- Small floor area required for installation due to high energy density
- For use in earthquake zones special approved racks are available

- If accommodated in battery rooms or cabinets the safety provisions specified in EN 50272-2 must be applied

- Recommended Range of Operation - 0°C to 55°C (preferred value 20°C)

Standards

- Conforms to IEC 896 Part 1
- Product Standard for Reference DIN 40739 (OGi monobloc batteries)

General Specifications

Type	Nominal Voltage (V)	Nominal Capacity (Ah)		Nominal Dimensions						Typical Weight		Electrolyte Volume		Short Circuit Current (A)	Internal Resistance (mΩ)
		10 hr rate to 1.80Vpc @ 20°C	8 hr rate to 1.75Vpc @ 77°F	Length		Width		Height ⁽¹⁾		kg	lbs	litres	US gallon		
Vb 12142	12	33	33	221	8.7	176	6.9	277	10.9	20.8	45.9	4.4	1.2	980	12.2
Vb 12143	12	50	50	221	8.7	176	6.9	277	10.9	24.8	54.7	4.3	1.2	1490	8.1
Vb 12144	12	66	66	311	12.2	176	6.9	277	10.9	33.7	74.3	6.3	1.7	1960	6.1
Vb 12146	12	100	100	389	15.3	176	6.9	277	10.9	45.6	100.5	7.9	2.1	2930	4.1
Vb 12147	12	117	117	469	18.5	176	6.9	277	10.9	53.5	118.2	9.7	2.6	3430	3.5
Vb 12149	12	150	150	553	21.8	176	6.9	277	10.9	65.5	144.4	11.7	3.1	4400	2.7
Vb 6157	6	191	191	284	11.2	229	9.0	332	13.0	45.8	101.0	10.1	2.7	3600	1.7
Vb 6159	6	246	246	284	11.2	229	9.0	332	13.0	51.6	113.8	9.2	2.5	4610	1.3

The electrical values shown in the table relate to loadings from a fully charged condition at ambient temperature of 20°C (unless otherwise specified).

⁽¹⁾Height includes connector.

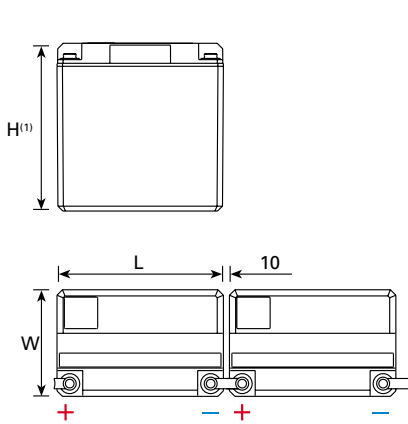

12V monobloc batteries
Vb 12142 - Vb 12149

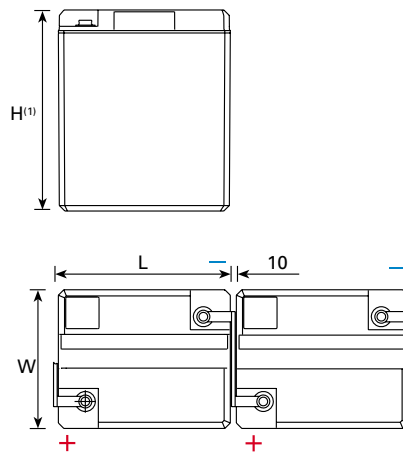

6V monobloc batteries
Vb 6157 & Vb 6159



www.enersysinc.com

Global Headquarters
P.O. Box 14145 Reading
PA 19612-4145
USA
Tel: +1-610-208-1991
+1-800-538-3627
Fax: +1-610-372-8613

EnerSys EMEA
Houtweg 26
1140 Brussels
Belgium
Tel: +32 (0)2 247 94 47
Fax: +32 (0)2 247 94 49

EnerSys Asia
49, Yanshan Road
Shekou, Shenzhen
Guangdong 518066
China
Tel: +86-755-2689 3639
Fax: +86-755-2689 8013

Contact: